

SMART Board™ for Flat-Panel Displays Interactive Whiteboard

Specifications – Model PX350 for Select 50" Flat Panels

NOTE: For a complete list of supported 50" flat panels, visit www.smarttech.com/products/overlay/specs.asp.

Physical Specifications

Size	SMART Board for Flat-Panel Displays Interactive Whiteboard (installed in landscape orientation only) Pen Tray (included) Interactive Whiteboard Mounting Bracket	54 1/4" W × 35 1/4" H × 2 3/8" D (137.8 cm × 89.5 cm × 6.0 cm) 3 5/8" (9.2 cm) added to bottom of overlay 4" (10.2 cm) added to front of overlay 50" W × 6 1/2" H × 3 11/16" to 6" D (127.0 cm × 16.5 cm × 9.4 cm to 15.2 cm)
Weight	Interactive Whiteboard, Mounting Bracket and Pen Tray	60 lb. (27.2 kg)
Shipping Size	Shipping Carton	58" W × 46 1/2" H × 21" D (147.3 cm × 118.1 cm × 53.3 cm)
Shipping Weight	Contents and Shipping Carton	116 lb. (52.6 kg)

All dimensions +/- 1/8" (3.2 mm). All weights +/- 2 lb. (0.9 kg).

Standard Features

Software	SMART Board software and Notebook™ software. Free software upgrades are available at www.smarttech.com/support/software/index.asp .
Pen Tray	Optical sensors in the pen tray detect when a pen or eraser is lifted from the tray. LED indicators show the active tool. Includes four Whisper-tip™ pens (black, blue, red and green) and one eraser. The pen tray connects to the interactive whiteboard with a MOD8 cable and connects to a computer with a 21'6" (6.5 m) USB Adapter cable. The USB Adapter cable has a DB9F connector at one end and a USB connector at the other. An optional serial cable is available. NOTE: The interactive whiteboard is also available without the pen tray. To order, add "NP" to the end of the model number. The pen tray is then replaced by an electronic controller that fastens behind the overlay bezel.
Display Control Strip	The display control strip allows you to initiate sleep mode, select the input source, toggle the display mode and access the panel control menu. This feature is only available for the Windows® operating system.
Mounting Bracket	The mounting bracket has an adjustable depth feature to accommodate most 50" flat panels installed in landscape orientation
Front Surface Material	Hard-coated, anti-glare polyester designed for optimal light transmission. Chemical and scratch resistant.
Digitizing Technology	DVIT™ (Digital Vision Touch) technology uses digital cameras to track an object interacting with the display surface
Flat Panel Connection	Serial cable included for flat panel control
Power Requirements	Switching power supply, 100V–250V AC, 47 Hz–63 Hz, 12V DC 4.2A, 6' (1.8 m) power cord
Power Consumption	Power consumption is up to 40 W
Certifications	CSA (Canada/U.S.)/CE
Warranty	One-year limited equipment warranty
Installation Notes	You can install the interactive whiteboard on a flat panel display that's securely mounted to a wall or floor stand. However, the wall mount or floor stand must be able to support a combined weight of 175 lb. (79.4 kg). Because of stability and mechanical fit issues, never use a table stand. You cannot attach speakers directly to the sides of a flat panel display when an interactive whiteboard is installed.

Computer Requirements

Windows Operating Systems	Pentium® 150 MHz processor (450 MHz or faster recommended) 128 MB of RAM (256 MB recommended) Available powered USB or serial port Approximately 160 MB of free hard disk space for a full installation Windows NT® 4.0 (SP6), Windows 98 operating system or later Microsoft Internet Explorer 5.0 or later Macromedia® Flash® player version 7.0.19 or later (recommended)
Requirements for SMART Video Player	Pentium 450 MHz processor (700 MHz or faster recommended) Windows 98 operating system or later. Does not run on the Windows NT operating system. Microsoft DirectX® 8.1 End-User Runtime or later
Macintosh Computers	400 MHz processor (800 MHz or faster recommended) 128 MB of RAM (256 MB recommended) Mac OS X version 10.1.5 or later (with Java™ version 1.3.1 update 1 or later) 50 MB of free hard disk space for minimum installation, 115 MB for complete installation with Gallery collections Available powered USB port NOTE: SMART Board software is not compatible with versions 10.3.0, 10.3.1 or 10.3.2 of the Mac OS X operating system. To use the handwriting recognition feature, you must have Mac OS X version 10.3.3 or later.

Specifications – Model PX350 for Select 50" Flat Panels

Storage and Operating Specifications

Storage	-40°F to 95°F (-40°C to 35°C) with up to 95% humidity non-condensing
Operation	41°F to 95°F (5°C to 35°C) with up to 90% humidity non-condensing

SMART Order Numbers

PX350	Interactive whiteboard and mounting bracket for select 50" flat panels
PX350NP	Overlay and mounting bracket without pen tray for select 50" flat panels
93-00360	Optional 20' (6.1 m), straight-through, DB9F-to-DB9F serial cable. Must be ordered separately for systems that don't support USB connections.

SMART Technologies Inc.

Suite 300, 1207 – 11th Avenue SW
Calgary, AB CANADA T3C 0M5
Main Switchboard: 1.888.42.SMART (Canada/U.S.) or +1.403.245.0333 (all other countries)
Support Tel: 1.866.518.6791 (Canada/U.S.) or +1.403.228.5940 (all other countries)
Support Fax: +1.403.806.1256
support@smarttech.com www.smarttech.com



SMART Board™ for Flat-Panel Displays Interactive Overlay

Specifications – Model PX350 for Select 50" Flat Panels

Front View

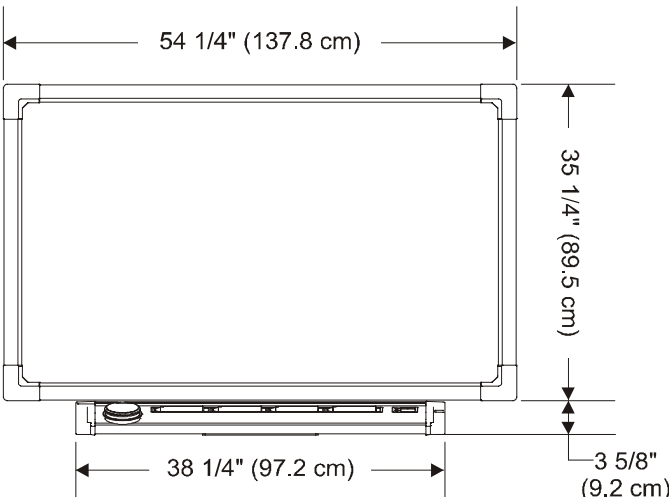

Side View

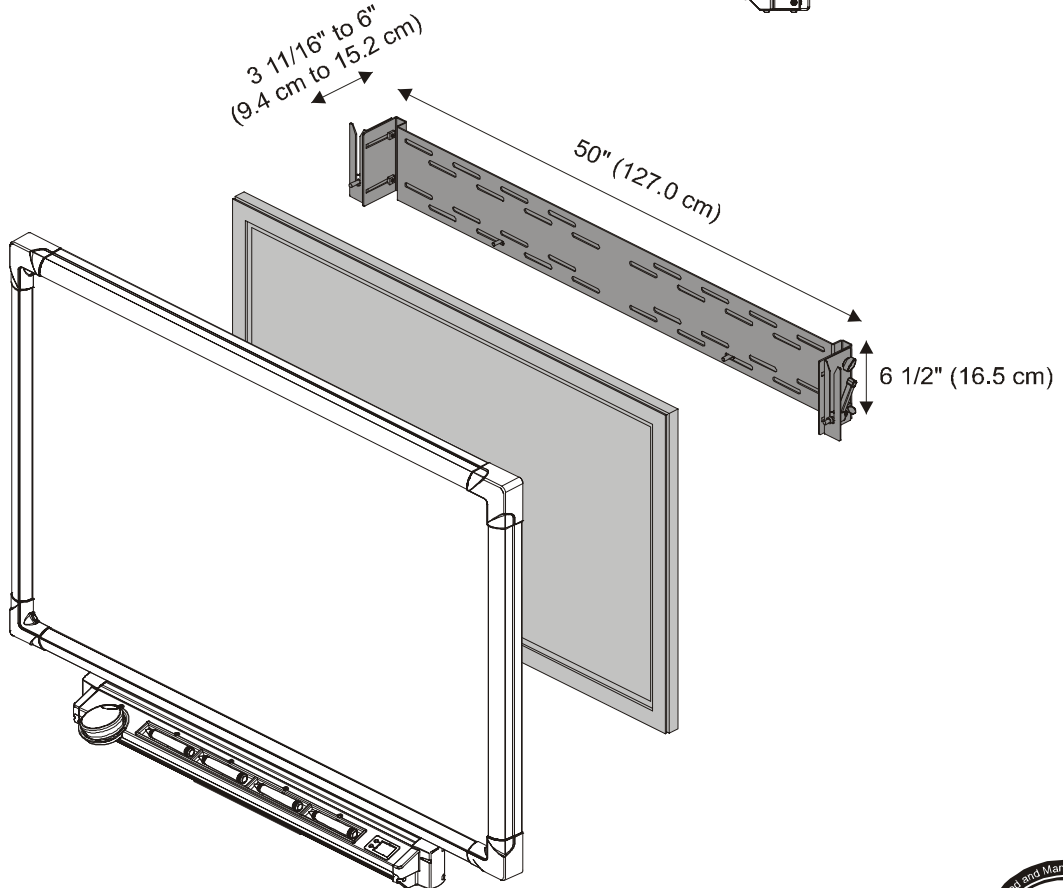
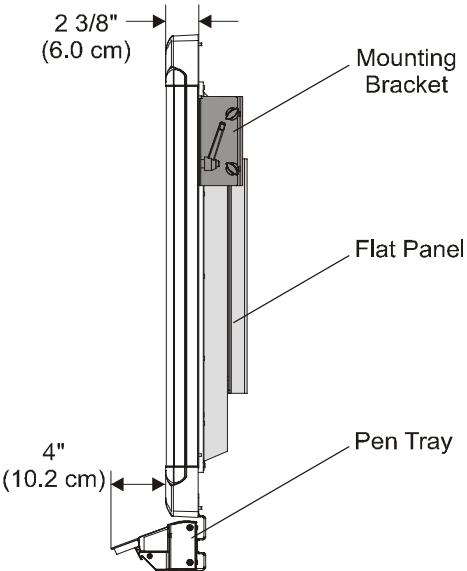

All dimensions are +/- 1/8" (3.2 mm).